

注意A1和A2二处，由于以前做的产品在A1处倒角过大，以及A2处比较粗糙，结果造成螺栓拧入后相关结合面不能完全密封。所以在今后的制造中，此二处要全检，保证100%合格。

REV 更改号	DATE 日期	REVISION DETAILS 更改内容	APPD 审核并批准
A	Feb. 2. 2016	Update the drawing	
B	Apr. 30. 2019	Change the surface treatment Change the chamfer of the thread end to 45 degree	
C	Mar. 25. 2022	Change the surface treatment	<i>nyf</i>

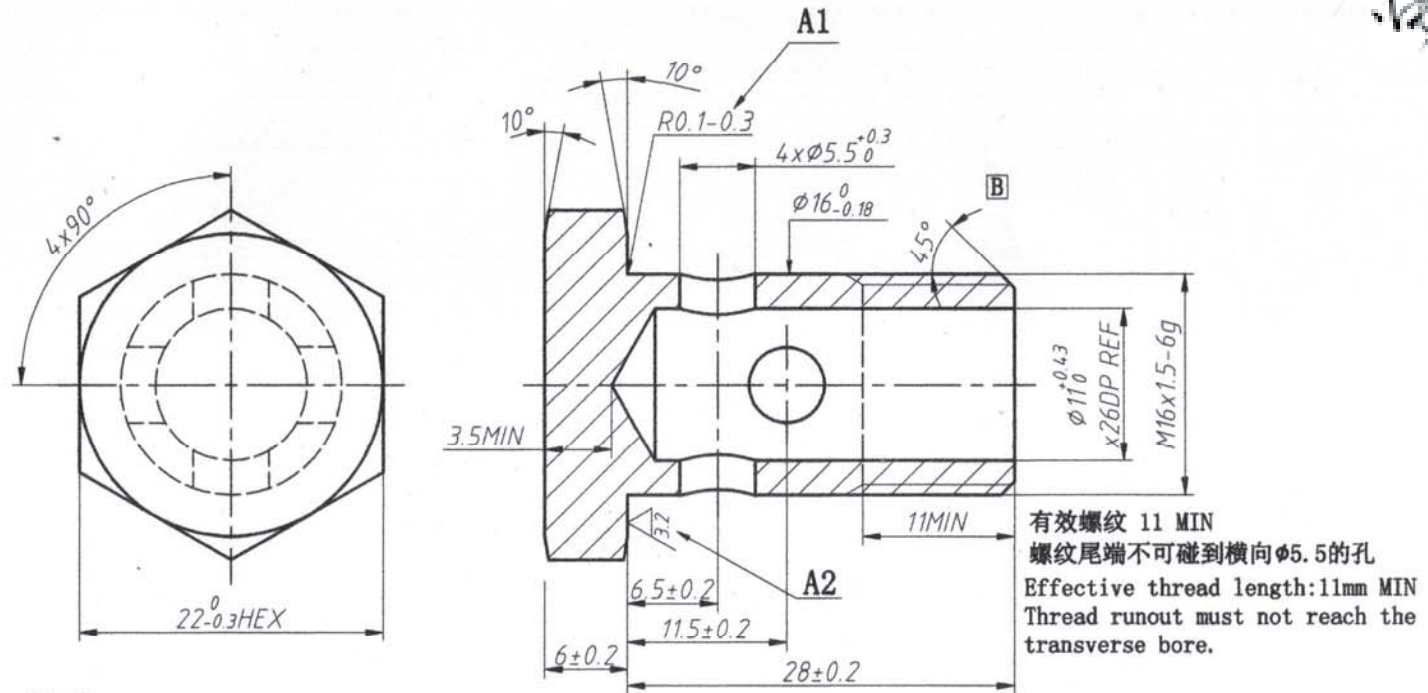

有效螺纹 11 MIN
螺纹尾端不可碰到横向Ø5.5的孔
Effective thread length: 11mm MIN
Thread runout must not reach the transverse bore.

UNLESS SPECIFIED
ALL DIMENSIONS ARE IN mm,
ROUGHNESS ON
HEXAGON SURFACE ∇ ,
INNER SURFACE OF THE BORE
BETWEEN Ra6.2 μ m AND Ra12.5 μ m,
OTHER MACHINED SURFACE Ra3.2 μ m,
ANGLES TOLERANCE $\pm 5^\circ$,
DIMENSIONS TOLERANCE ± 0.25 mm,
REMOVE ALL BURRS, SLIVERS AND SWarf,
BREAK ALL SHARP EDGES R<0.5mm.

其它事项,
图示尺寸单位为mm,
六角面粗糙度 ∇ ,
内孔表面粗糙度Ra6.2-Ra12.5,
其它未注机加工表面粗糙度 Ra-3.2 μ m,
未注角度公差 $\pm 5^\circ$,
未注尺寸公差 ± 0.25 mm
去除所有毛刺及金属切屑,
锐边倒钝R<0.5mm.

Zhejiang Gaocheng Autoparts Co.,Ltd	
PART No 零件名	80130-M16
SCALE:	APPD: <i>EE</i> N: 批准 <i>nyf</i> 图 余德胜
NTS	DATE: 2022. 03. 25 日期 审核 詹永斌

MATERIAL	Chinese steel 45	材质: 45#
FINISH	ZINC PLATING WITH 8um MICRONS MINIMUM PLATING THICKNESS AND TRIVALENT CHROMATE PASSIVATION AND WITHSTAND 96 HRS TO WHITE / 360 HS TO RED RUST IN SALT SPRAY TEST. C	镀锌, 三价铬钝化, 银白色, 盐雾试验96小时无白斑, 360小时无红锈, 镀锌层厚度大于8um.